

SKIPPERS' PLAN RACE WEEK

LYRA 2007 Regatta

Hosted by
Ashbridge's Bay Yacht Club

30 Ashbridge's Bay Park Road
Toronto, Ontario, Canada M4L 3W6

July 29th – August 5th, 2007

Sailing Instructions

Table of Contents

GENERAL CONDITIONS	2
1. RULES.....	2
2. ADVERTISING.....	2
3. NOTICES TO COMPETITORS.....	3
4. CHANGES IN SAILING INSTRUCTIONS & DIVISION SPLITS.....	3
5. SIGNALS MADE ASHORE.....	3
6. LAUNCH DEADLINE.....	7
7. SCHEDULE OF RACES.....	4
8. RACING AREA.....	5
9. RETIREMENTS.....	5
10. COURSES.....	5
11. MARKS	5
12. THE START.....	5
13. CHANGE OF COURSE AFTER THE START.....	5
14. THE FINISH.....	6
15. SUNSET & SUNRISE.....	6
16. PROTESTS.....	6
17. MEDIATION.....	7
18. PENALTY SYSTEMS.....	7
19. SCORING.....	8
20. TIME LIMITS.....	8

21. SUPPORT BOATS-----	8
22. HAUL-OUT RESTRICTIONS-----	8
23. COMMUNICATION-----	8
24. RESPONSIBILITY-----	9
25. INSURANCE-----	9
26. PHOTOGRAPH & VIDEO RIGHTS-----	9
27. PRIZES-----	9
APPENDIX A: THE FOUNDER’S CUP RACE.....	10
APPENDIX B: THE CENTENNIAL RACE.....	12
APPENDIX C: THE FREEMAN CUP RACE, LONG COURSE.....	14
APPENDIX D: THE FREEMAN CUP RACE, SHORT COURSE.....	17
APPENDIX E: THE DAY COURSE RACES.....	20
APPENDIX F: CHAMPIONSHIP RULES AND SCORING GUIDELINES.....	28

These Sailing Instructions shall apply to the Founders Cup Race, Centennial Race, Freeman Cup Race – Long Course, Freeman Cup Race – Short Course, 3-Day Course Race Series, and 2-Day Course Race Series. Sections 1 – 25 shall apply to all races. Additional specific instructions for each race or series are included in the Appendices.

GENERAL CONDITIONS

The safety of a boat and its crew is the sole responsibility of the owner(s) and/or skipper, who will ensure that the boat is fully found, thoroughly seaworthy and manned by an experienced crew physically fit to face bad weather.

The owner/skipper shall be satisfied as to the soundness of the hull, spars, rigging, sails and gear. The owner/skipper will ensure that all safety equipment is properly maintained and stowed and that the crew is familiar with its location and use.

It is the sole and exclusive responsibility of the skipper and crew of each boat to decide whether or not to start, continue in or retire from a race. The skipper is also responsible for the conduct of crew and guests while on the property of any yacht club.

1 RULES

1.1 The regatta will be governed by the ‘rules’ as defined in the Racing Rules of Sailing 2005-2008 and the 2006-2007 ISAF Offshore Special Safety Regulations. The 2006-2007 ISAF Offshore Special Regulations may be found at:

www.sailing.org/offshore/2006/osR2006_complete_161205.pdf

1.2 In the event of a conflict between the Sailing Instructions and the Notice of Race, the Sailing Instructions shall prevail.

1.3 The prescriptions of the Canadian National Authority, the Canadian Yachting Association, will apply. They will be posted on the Official Notice Board of the Regatta and are at

1.4 The requirement for national letters shall not apply. This changes *rule* G 1.1 (b)

1.5 Any questions about these Sailing Instructions must be submitted in writing to the Ashbridges' Bay Yacht Club / LYRA Principal Race Officer. The questions and answers, if applicable, will be posted on the ABYC official notice board and, for the Centennial and Founder's Races, on the notice boards at Port Credit Yacht Club and Youngstown Yacht Club, respectively, located as per Sailing Instruction 3.

1.6 Individual Class Association Rules will apply.

2 ADVERTISING

2.1 The ISAF Advertising Category for each class will be as specified in the Class Rules. If no Advertising Category is specified in Class Rules, Category C will apply.

3 NOTICES TO COMPETITORS

3.1 Notices to competitors will be posted on the Official Notice Board(s) located as follows:

- a) Founders Cup Race: Port Credit Yacht Club: at the base of the staircase
- b) Centennial Race: Youngstown Yacht Club: on the main floor of the clubhouse
- c) Freeman Cup and LYRA Day Course Races: ABYC - upstairs on main floor

4 CHANGES IN SAILING INSTRUCTIONS & DIVISION SPLITS

4.1 Any changes in the Sailing Instructions and notice of division assignments will be posted by the following times:

- a) Founder's Cup Race - 0800 hrs Saturday, July 28 at Port Credit Yacht Club
- b) Centennial Race - 0800 hrs Sunday, July 29 at Youngstown Yacht Club
- c) Freeman Cup Races - 0800 hrs Tuesday, July 31 at ABYC
- d) Day Course Races - any change to the Sailing Instructions shall be posted before 0800 hrs on the day it will take effect. Division assignments and any change to the Schedule of Races shall be posted before 1800 hrs the day before they will take effect.

5 SIGNALS MADE ASHORE

5.1 Signals made ashore will be displayed from the flagpole in front of the respective starting club.

5.2 Code Flag "AP", Answering Pennant, with two sound signals (one when lowered) means "the race is postponed and yachts are to remain in the harbor." The warning signal will be made not less than 60 minutes after "AP" is lowered.

6 LAUNCH DEADLINE

6.1 All boats participating in the Day Races shall be afloat before 0900 hrs. on the day that their class begins racing.

7 SCHEDULE OF RACES

7.1 Founders Cup Race: Sunday, July 29, 2007

Registration/Check-in: 0830-1000 hrs, Sunday, July 29 @ Port Credit Y C
Competitor's Meeting: none
First Warning: 1100 hrs, Sunday, July 29
Time limit: 2000 hrs, Sunday, July 29

7.2 Centennial Cup Race: Monday, July 30, 2007

Registration/Check-in: 1700-1900 Sunday July 29, 0830-1000 Monday July 30 at Youngstown YC
Competitor's Meeting: none
First Warning: 1100 hrs, Monday July 30
Time limit: 2000 hrs, Monday July 30

7.3 Freeman Cup Races: Wednesday, August 1, 2007

Registration/Check-in: 1800-2000 hrs, Tuesday July 31 at ABYC
1400-1800 hrs, Wednesday, August 1 at ABYC
Competitor's Meeting: none
Crew Lists: Final Crew Lists must be submitted by 1800 hrs, Wednesday, August 1
First Warning: Long Course: 1900 hrs, Wednesday, August 1
Short Course: Immediately following the last start for the Long Course
Time limit (long and short courses): 0100 hrs, Friday August 3

7.4 Three-Day Course Racing: Friday, August 3 – Sunday, August 5, 2007

Registration/Check-in: 1500-2000 hrs, Thursday, August 2 @ ABYC
0800-1000 hrs, Friday, August 3 @ ABYC
First Warning: 1100 hrs, Friday, August 3
1030 hrs, Saturday, August 4
1030 hrs, Sunday, August 5

No start sequence will commence after 1530 hours on Friday or Saturday, or after 1330 hours Sunday.

7.5 Two-Day Course Racing: Saturday, August 4 - Sunday, August 5, 2007

Registration/Check-in: 1700-2000 hrs, Friday, August 3 @ ABYC
0730-0900 hrs, Saturday, August 4 @ ABYC
First Warning: 1030 hrs, Saturday, August 4
1030 hrs, Sunday, August 5

No start sequence will commence after 1530 hours on Saturday, or after 1330 hours Sunday.

7.6 AWARDS PRESENTATIONS

7.6.1 Awards for the Long Distance Races will be presented on Friday evening, August 3rd at approx. 1800 hrs. on the outside patio at ABYC. Awards for the Day Course Race

Series will be presented on Sunday afternoon, August 5th at approx. 1600 hrs. on the outside patio at ABYC.

8 RACING AREA

8.1 The racing area will be in the waters of Lake Ontario for all races.

9 RETIREMENTS

9.1 Boats retiring from the Founders Cup, the Centennial Race, or the Freeman Cup Races shall report their retirement to race headquarters at the first possible opportunity, either by VHF on channel 71 or by cell phone to (416) 436-8709.

10 COURSES

10.1 The courses are described in Appendices A – E. Note that coordinates indicated for specific marks are given for reference only and are believed accurate. Errors in these coordinates shall not be grounds for redress. This changes *rule* 60.1.

11 MARKS

11.1 Marks and their locations for each race are specified in Appendices A – E.

12 THE START

12.1 Races will be started using the instructions in Appendices A-E. The starting line locations are also described in Appendices A – E.

12.2 The starting line for each race will be as specified in Appendices A-E.

12.3 A boat whose preparatory signal has not been made shall keep clear of the starting area and of all boats whose preparatory signal has been made.

12.4 A boat starting later than 4 minutes after her starting signal will be scored Did Not Start. This changes *rule* A4.

12.5 Recalled divisions shall restart **after** the final scheduled start. This changes *rule* 29.2.

12.6 In the event of an individual recall, the Race Committee may announce via VHF and/or loud hailer the sail number and/or boat name of each premature starter. See Appendices A-E for applicable VHF channels for each race. Failure of a boat to hear her recall, or the Race Committee to announce individual recalled boats, shall not be grounds for protest or redress. This changes *rule* 62.1(a).

13 CHANGE OF COURSE AFTER THE START

13.1 Course changes for the Day Course Race Series will be made in accordance with *rule* 33. In the event of a change of course, new marks for each course will correspond to the mark information in Appendices E1 to E5.

14 THE FINISH

- 14.1** For the Founders, Centennial, and Freeman Cup Races, the finish line will be between a staff displaying an orange flag or shape on a Race Committee boat, and the finish mark as described in Appendices A, B, C & D.
- 14.2** For the Day Course Races, the finishing line will be between a staff displaying an orange flag or shape on the RC boat and the finishing mark as described in Appendix E. The flag “H”, when displayed over a division flag while boats are finishing, indicates that that division will not sail another race that day. Flag “H” flown alone indicates that no more races will be sailed on that course. This changes *rule* Race Signals.

15 SUNSET & SUNRISE

- 15.1** For the Freeman Cup Long and Short Course Races, the individual race instructions (Appendices C and D) state the times of sunset and sunrise, Eastern Daylight Time. At sunset, or five (5) minutes after a yacht’s start, whichever occurs later, *rule* 17 will be replaced by the following until sunrise:

When two yachts on the same tack are within three overall lengths (of the larger yacht) of each other, the yacht being overtaken shall maintain her proper course. The overtaking yacht shall keep clear and shall neither bear away nor luff toward the other.

16 PROTESTS

- 16.1** Protests will be written on Canadian Yachting Association protest forms. These forms will be available at the ABYC Information Centre on the lower floor of the clubhouse.
- 16.2** Protests for the Centennial Race and the Founders Cup must be filed at the ABYC Information Centre within 1 ½ hours of the expiration of the time limit for each race, or of the finish time of the last boat in that race, whichever is earlier.
- 16.3** Protests for the Freeman Cup Races (Long and Short Courses) must be filed at the ABYC Information Centre within 1 ½ hours after the protestor finishes, if the protestor finishes before 2000 hrs Thursday August 2. If the protestor finishes after 2000 hrs Thursday, protests must be filed by 0930 Friday August 3.
- 16.4** Protests for the Day Course Races on each course shall be filed at the ABYC Information Center within one hour after the respective Race Committee boat for that course has arrived and docked at ABYC. The official arrival time of each Race Committee Boat will be posted on the official notice board. The same time limit shall apply for protests lodged by the Race Committee.
- 16.5** Protests for the Founders Cup, the Centennial Race, and the Freeman Races (Long and Short Courses) will be heard as soon as practicable after completion of the day races on Friday August 3.
- 16.6** The proposed schedule of protest hearings for Long Distance and Day Course Races will be posted on the ABYC Notice Board within 30 minutes following the end of protest filing time to inform competitors as to the time and place of hearings in which they are parties or

witnesses. It is each boat's sole responsibility to check the official notice board at the end of the filing time to see if she is cited in a protest. Failure of any competitor to appear when called for a hearing will be considered by the Protest Committee as grounds for proceeding under *rule* 66.3(b).

16.7 For the Day Course Races, on the last day of the Regatta a request for reopening a hearing shall be delivered:

16.7.1 within the protest time limit if the party requesting the reopening was informed of the decision on the previous day

16.7.2 no later than 30 minutes after the party requesting reopening was informed of the decision on that day. This changes *rule* 66.

16.8 For the Day Course Races, no measurement protests will be accepted after the end of the protest time indicated in Sailing Instruction 15.4 on the first day of racing for that division or class. This changes *rule* 60.1.

16.9 Protestors protesting a violation of a class rule are responsible for providing an up-to-date copy of the class rules to the protest committee.

17 MEDIATION

17.1 For Protests under a rule of Part 2 of the *rules* where there is no damage, and in which there are no more than two boats involved, there may be a short mediation hearing. Any Protest not resolved by this process will be referred to the Protest Committee for a full hearing.

17.2 After the Protest has been properly filed as per paragraph 15.2, 15.3, or 15.4, the designated representative from each boat shall testify before a mediator. No witnesses will be permitted. The mediator will decide on the validity of the Protest(s). This changes *rule* 63.5.

17.3 A boat that accepts the opinion of the arbitrator that she has broken a *rule* of Part 2 of the *rules*, and accepts fault, shall receive a 40% scoring penalty calculated per *rule* 44.3 (c). This changes *rule* 44.3 (c).

17.4 When one boat accepts a penalty following a mediation hearing, her decision shall be binding upon the other party to the Protest, and the Protest shall not be referred to the Protest Committee. This changes *rule* 63.1.

17.5 The mediator may also approve the withdrawal of a Protest. This changes *rule* 63.1

17.6 The mediator may attend the full hearing. This changes *rule* 63.3 (a).

18 PENALTY SYSTEMS

18.1 For all Day Course Races, the Two-Turns Penalty (*rule* 44.2) shall apply; except that for the Martin 16 class *rules* 44.1 and 44.2 are changed so that only one turn, including one tack and one gybe, is required.

18.2 For the Centennial Race, Founders Cup Race, Freeman Cup Race - Long Course, and Freeman Cup Race - Short Course, the Percentage Scoring Penalty (*rule* 44.3) shall apply, except that the percent penalty shall be 40%. This changes *rule* 44.3 (c).

19 SCORING

19.1 Races will be scored using the Low Point Scoring System of Appendix A of the *rules*, except that for all Day Course Race Series, each boat's series score will be the total of all her individual race scores, excluding her worst score only if six (6) or more races are completed.

19.2 PHRF classes will be scored using time-on-time handicaps provided by PHRF-LO.

19.3 The IRC Rules Parts 1, 2, and 3 shall apply.

19.4 For scoring purposes, DSQ shall receive points equal to the total number of registered boats in that division or class plus two (2). DNF shall receive points equal to the total number of finishers in that division plus one (1). These change *rule* A4.2.

19.5 Scoring for LYRA championships is described in Appendix F of this document.

20 TIME LIMITS

20.1 Time limits will be in effect for all races as specified in Appendices A – E.

21 SUPPORT BOATS

21.1 Team leaders, coaches and other support personnel shall not be within 100 yards of the race courses defined in Appendix E, unless called upon for safety reasons. They are to remain outside the courses from the time of the preparatory signal for the first class to start until all boats have finished or the Race Committee signals a postponement, or abandonment. The penalty will be at the discretion of the Protest Committee.

22 HAUL-OUT RESTRICTIONS

22.1 Boats may **not** be hauled during the Regatta without the permission of the Principal Race Officer or Protest Committee Chair. An exception may be granted to One-Design boats that are normally hauled between race days during the Day Race Series. A list of such One-Design classes will be posted by the Principal Race Officer on the official notice board.

23 COMMUNICATION

23.1 While racing, a boat shall neither make radio, telephone or computer transmissions, nor receive radio, cell phone or computer communications not available to all boats, except in the case of a life-threatening emergency. The only other exception is that a crew member may place or receive a cell phone call of a personal nature that does not involve the exchange of information which could affect the boat's outcome in the race. Any penalty under this instruction will be at the discretion of the Protest Committee.

23.2 Boats racing in the Freeman Cup-Long Course and Freeman Cup-Short Course races which expect to finish before 0700 hrs, Thursday, August 3rd, are requested to notify the Race

Committee two hours before their anticipated arrival time via a cell phone call to (416) 436-8709, or by radio on VHF Channel 71.

- 23.3** The Race Committee may make announcements on the water using the VHF radio channels specified in Appendices A-E. Note that such announcements are a courtesy only, and the failure of the Race Committee to make announcements shall not be grounds for granting redress. This changes *rule* 62.1 (a)

24 RESPONSIBILITY

- 24.1** Sailing is an activity that has an inherent risk of damage and injury. Competitors in this event are participating entirely at their own risk. See *rule* 4, Decision to Race. The Regatta Organizers (LYRA, ABYC, the Race Committee, and Protest Committee, sponsors or any other organization or official) will not be responsible for damage to any boat or other property or the injury to any competitor, including death, sustained as a result of participation in this event. By participating in this event, each competitor agrees to release the Regatta Organizers from any and all liability associated with such competitor's participation in this event, to the fullest extent permitted by law.

25 INSURANCE

- 25.1** The safety of a boat, her crew and entire management shall be the sole and inescapable responsibility of the owners or owner's representative.
- 25.2** Each boat is required to hold adequate third-party insurance and it is the owner or owner's representative's sole and inescapable responsibility to ensure that the insurance is in place and is adequate prior to participating in this event. LYRA or the ABYC Registrar may request a copy of the insurance binder.

26 PHOTOGRAPH & VIDEO RIGHTS

- 26.1** All marks, pictures, video and audio recordings, graphic logos and service names contained herein or produced during the Regatta by or on behalf of LYRA or ABYC is property of either LYRA or ABYC or their respective members. No rights are granted to use marks, pictures, graphic logos and service names without permission.

27 PRIZES

- 27.1** Prizes will be awarded as specified in Appendix F of this document.

Appendix A

The Founders Cup Race

Sunday, July 29th, 2007

A1. THE COURSE

A1.1 From the Starting Line off Port Credit Yacht Club, leaving the Lake Ontario West ODAS Light Buoy to port, to the Finishing Line near the entrance to Ashbridge's Bay Yacht Club.

A1.2 The Lake Ontario West ODAS Light Buoy is a large weather observation buoy located at 43° 25.38' N, 79° 22.60' W, or approximately 11 NM from the Gibraltar Buoy on a bearing of 188°.

A2. DIVISIONS

A2.1 All divisions will sail the same course. Each division shall be designated by the RC signal boat by a numeral pennant indicating the division number. Divisions will start in numerical order, but this may be changed at the discretion of the Race Committee, and shall not be grounds for protest or redress. This changes *rule* 62.1 (a).

A2.2 Division splits and starting order will be posted on the official notice board at the Port Credit Yacht Club per Sailing Instruction 4.

A3. THE START

A3.1 The start will be between the orange flag on the Race Committee boat to starboard and an inflatable mark to port located approx. 0.5 NM on a compass bearing of 140° magnetic from the entrance to Port Credit Yacht Club..

A3.2 Code Flag F (attention signal) will be displayed with one sound signal five (5) minutes before the Warning Signal for the first division to start. Code Flag F will be lowered with one sound signal one minute before the Warning Signal is made for the first division. This changes *rule* 26.

A3.3 Start Sequence:

The races will be started in accordance with *rule* 26 and Instruction A2.1, as follows:

A.3.3.1 For each Division, the Warning Signal will be made 5 minutes before the starting signal.

A3.3.2 There will be a minimum of one (1) minute between the Start of one Division and the Warning for the next Division

A4. THE FINISH

- A4.1 The finish will be between the orange flag on the Race Committee boat to starboard and an inflatable mark to port, located at approximately 43° 38.877' N 79° 18.338' W or 0.5 NM on a bearing of 160° magnetic from the entrance to Ashbridges' Bay Yacht Club.
- A4.2 In the event that the Race Committee finish boat is not on station, each boat finishing shall take her own time as she passes abeam of the mark leaving it to the Port side not more than 100 Feet away. All such times shall be reported to the ABYC Information Center within two (2) hours of finishing.

A5. TIME LIMIT

For the Founders Cup Race, the time limit will be 2000 hours, Sunday, July 29th, 2007.

A6. RADIO COMMUNICATIONS

The applicable VHF channel for this course is 71

Appendix B

The Centennial Race

Monday July 30, 2007

B1. THE COURSE

B1.1 From the Starting Line near the mouth of the Niagara River, to the finish near the entrance to Ashbridge's Bay Yacht Club.

B2. DIVISIONS

B2.1 All divisions will sail the same course. Each division shall be designated by the RC signal boat by a numeral pennant indicating the division number. Divisions will start in numerical order, but this may be changed at the discretion of the Race Committee, and shall not be grounds for protest or redress. This changes *rule* 62.1 (a).

B2.2 Division splits and starting order will be posted on the official notice board at the Youngstown Yacht Club per Sailing Instruction 4.

B3. THE START

B3.1 The start will be between the orange flag on the Race Committee boat to starboard and an inflatable mark to port, in the area of Navigation Mark "R 2" off the entrance to the Niagara River

B3.2 Navigation Mark "R 2" is located at approximately 43°19.040' N, 79°04.235' W

B3.3 Code Flag F (attention signal) will be displayed with one sound signal five (5) minutes before the Warning Signal for the first division to start. Code Flag F will be lowered with one sound signal one minute before the Warning Signal is made for the first division. This changes *rule* 26.

B3.4 Start Sequence:

The races will be started in accordance with *rule* 26 and Instruction B2.1, as follows:

B3.4.1 For each Division, the Warning Signal will be made 5 minutes before the starting signal.

B3.4.2 There will be a minimum of one (1) minute between the Start of one Division and the Warning for the next Division.

B4. THE FINISH

B4.1 The finish will be between the orange flag on the Race Committee boat to starboard and an inflatable mark to port, located at approximately 43°38.877' N 79°18.338' W or 0.5 NM on a bearing of 160° magnetic from the entrance to Ashbridge's Bay Yacht Club.

B4.2 In the event that the Race Committee is not on station, each boat finishing shall take her own time as she passes abeam of the finish mark leaving it to port at a bearing of 90 from the direction of the last mark, not more than 100 feet away. All such times shall be reported to the ABYC Information Center within two (2) hours of finishing.

B5. TIME LIMIT

For the Centennial Race, the time limit will be 2000 hours, Monday July 31, 2007.

B6. RADIO COMMUNICATIONS

The applicable VHF channel for this course is 71

Appendix C

The Freeman Cup Race - Long Course

Wednesday, August 1st, 2007

C1. THE COURSE

C 1.1 BUOYS TO PORT (Red flag on Committee Boat)

From the start, leaving the Port Credit Mark, the Lake Ontario West ODAS Light Buoy, the Niagara Mark, and the Whitby Mark all to port, to the finish.

C1.2 BUOYS TO STARBOARD (Green flag on Committee Boat)

From the start, leaving the Whitby Mark, the Niagara Mark, the Lake Ontario West ODAS Light Buoy, and the Port Credit Mark all to starboard, to the finish.

C1.3 MARKS

C 1.3.1 The Lake Ontario West ODAS Light Buoy is a large weather observation buoy located at approximately 43° 25.38'N, 79° 22.60'W, or approximately 11 NM on a bearing of 188° magnetic from the Gibraltar buoy.

C 1.3.2 The Niagara Mark is the red navigational mark “R 2” (Fl R 4 s) located at approximately 43°19.040' N, 79° 04.235' W off the mouth of the Niagara River.

C 1.3.3 The Whitby Mark is a 16ft blue dinghy with a 10 foot mast and a solid orange light, located at approximately 43° 50.230'N, 79° 04.206'W in the waters off the Whitby Yacht Club.

C 1.3.4 The Port Credit Mark is a 16ft dinghy with a 10 foot mast and an orange light, located at approximately 43° 33.095'N 79°33.468' W in the waters off the Port Credit Yacht Club.

C2. SUNRISE & SUNSET

C2.1 Sunset, Wednesday, August 1st is scheduled for **2032** hrs EDT.

C2.2 Sunrise, Thursday, August 2nd is scheduled for **0602** hrs EDT.

C3. DIVISIONS

C3.1 All divisions will sail the same course. Each division shall be designated by the RC signal boat by a numeral pennant indicating the division number. Divisions will start in numerical order, but this may be changed at the discretion of the Race Committee, and shall not be grounds for protest or redress. This changes *rule* 62.1 (a).

C3.2 Division splits and starting order will be posted on the official notice board at Ashbridges' Bay Yacht Club per Sailing Instruction 4.

C4. THE START

C4.1 The starting line will be between the orange flag on the Race Committee boat to Starboard and an inflatable mark to port, located approximately 1.7 NM on a bearing of 160 magnetic from the entrance to ABYC.

C4.2 Code Flag F (attention signal) will be displayed with one sound signal five (5) minutes before the Warning Signal for the first division to start. Code Flag F will be lowered with one sound signal one minute before the Warning Signal is made for the first division. This changes *rule* 26.

C4.3 Start Sequence:

The races will be started in accordance with *rule* 26 and Instruction C3.1, as follows:

C4.3.1 For each Division, the Warning Signal will be made 5 minutes before the starting signal.

C4.3.2 There will be a minimum of one (1) minute between the Start of one Division and the Warning for the next Division.

C5. MARK ROUNDINGS

C5.1 A boat shall log times of rounding marks and crossing the Finish Line. At least two (2) members of the crew shall actually see and identify the mark being rounded in order that the boat may claim to have rounded.

C5.2 When rounding marks or finishing after sunset and before sunrise, a strong light shall be shown on sail numbers for at least thirty (30) seconds. In conditions of poor visibility, it shall be the responsibility of the skipper of a boat that is finishing to ensure, by radio contact or other means, that the boat has been observed and correctly identified by the Race Committee.

C6. THE FINISH

C6.1 The Finishing Line will be between the staff displaying an orange flag on the Race Committee boat to starboard and an inflatable mark to port. It will be located at approximately 43° 38.877' N 79° 18.338' W or 0.5 NM on a bearing of 160° magnetic from the entrance to Ashbridges' Bay Yacht Club.

C6.2 In the event that the Race Committee is not on station, each boat finishing shall take her own time as she passes abeam of the finish mark, leaving it to port at a bearing at a 90⁰ magnetic from the direction of the last mark, no farther than 100 feet away. All such times shall be reported to the ABYC Information Center within two (2) hours of finishing.

C7. TIME LIMIT

For the Freeman Cup Race – Long Course, the time limit will be 0100 hours, Friday August 3, 2007.

C8. CREW LIST

All yachts competing in this race **must** submit a complete crew list with names, addresses, and contact telephone numbers of all aboard. Crew lists may be submitted to the ABYC Registrar at the time of registration/check-in, or delivered to the ABYC Information Center by 1800 hrs., August 1st, 2007. ***Any yacht failing to submit a crew list by 1800 hrs. on Wednesday, August 2nd, 2006, will not be scored.***

C9. RADIO COMMUNICATIONS

The applicable VHF channel for this course is 71.

The Freeman Cup Race - Short Course

Wednesday, August 1st, 2007

D1. THE COURSE

D1.1 BUOYS TO PORT (Red flag on the Committee boat)

From the start, leaving the Port Credit Mark, the Lake Ontario West ODAS Light Buoy, and the Niagara Mark to port, to the finish.

D 1.2 BUOYS TO STARBOARD (Green flag on the Committee boat)

From the start, leaving the Niagara Mark, the Lake Ontario West ODAS Light Buoy and the Port Credit Mark to starboard, to the finish.

D1.3 MARKS

D 1.3.1 The Port Credit Mark is a 16ft dinghy with a 10 foot mast and an orange light, located at approximately 43° 33.095'N 79°33.468' W in the waters off the Port Credit Yacht Club.

D 1.3.2 The Lake Ontario West ODAS Light Buoy is a large weather observation buoy located at approximately 43° 25.384'N, 79° 22.573'W, or approximately 11 NM on a bearing of 188° magnetic from the Gibraltar buoy.

D 1.3.3 The Niagara Mark is the red navigational mark “R 2” (Fl R 4 s) located at approximately 43°19.040' N, 79°04.235' W off the mouth of the Niagara River.

D2. SUNRISE & SUNSET

D2.1 Sunset, Wednesday, August 1st is scheduled for **2032 hrs.** EDT.

D2.2 Sunrise, Thursday, August 2nd is scheduled for **0602 hrs.** EDT.

D3. DIVISIONS

D3.1 All divisions will sail the same course. Each division shall be designated by the RC signal boat by a numeral pennant indicating the division number. Divisions will start in numerical order, but this may be changed at the discretion of the Race Committee, and shall not be grounds for redress. This changes *rule* 62.1 (a).

D3.2 Division splits and starting order will be posted on the official notice board at Ashbridges' Bay Yacht Club per Sailing Instruction 4.

D4. THE START

- D4.1 The start will be between the orange flag on the Race Committee boat to starboard and an inflatable mark to port located approximately 1.7 NM on a bearing of 160° magnetic from the entrance to Ashbridges' Bay Yacht Club.
- D4.2 Code Flag F (attention signal) will be displayed with one sound signal five (5) minutes before the Warning Signal for the first division to start. Code Flag F will be lowered with one sound signal one minute before the Warning Signal is made for the first division. This changes *rule 26*.
- D4.3 **Start Sequence:**

The races will be started in accordance with *rule 26* and Instruction D3.1, as follows:

- D4.3.1 For each Division, the Warning Signal will be made 5 minutes before the starting signal.
- D4.3.2 There will be a minimum of one (1) minute between the Start of one Division and the Warning for the next Division.

D5. MARK ROUNDINGS

- D5.1 Buoys and marks shall be left to port when sailing the Buoy to Port Course, and to Starboard when sailing the Buoy to Starboard Course.
- D5.2 A boat shall log times of rounding marks and crossing the Finish Line. At least two (2) members of the crew shall actually see and identify the mark being rounded in order that the boat may claim to have rounded.
- D5.3 When rounding marks or finishing after sunset and before sunrise, a strong light shall be shown on sail numbers for at least thirty (30) seconds. In conditions of poor visibility, it shall be the responsibility of the skipper of a boat finishing to ensure by radio contact or other means, that the boat has been observed and correctly identified by the Race Committee.

D6. THE FINISH

- D6.1 The Finishing Line will be between the staff displaying an orange flag on the Race Committee signal boat to starboard and an inflatable mark to port. It will be located at approximately 43°38.877' N 79°18.338' W or 0.5 NM on a bearing of 160° magnetic from the entrance to Ashbridges' Bay Yacht Club. See D4.1 At night, the RC signal boat shall shine a light on the RC flag at all times, along with her navigation lights.
- D6.2 In the event that the Race Committee is not on station, each boat finishing shall take her own time as she passes abeam of the mark leaving it to port no further than 100 feet away at a bearing of 90 from the directing of the last mark. All such times shall be reported to the ABYC Information Center within two (2) hours of finishing.

D7. TIME LIMIT

For the Freeman Cup Race – Short Course, the time limit will be 0100 hours, Friday August 3, 2007.

D8. CREW LIST

All yachts competing in this race must submit a complete crew list with names, address, and contact telephone numbers of all aboard. Crew lists may be submitted at time of registration/check-in, or delivered to the ABYC Information Center by 1800 hrs., Wednesday, August 1st, 2007. *Any yacht failing to submit a crew list by 1800 hrs. on Wednesday, August 1st, 2007, will not be scored.*

D9. RADIO COMMUNICATIONS

The applicable VHF channel for this course is 71.

Appendix E

The Day Course Race Series (2 & 3-Day)

August 3rd to August 5th, 2007

E1. COURSES

- E1.1 There will be Five (5) course areas designated “A”, “B”, “C”, “D”, and “E”. Assignments of classes and divisions to courses will be posted by 0800 Thursday August 2 on the Official Notice Board at ABYC.
- E 1.2 Detailed information on each course, including the course location, is given in Appendix E1 to E5 respectively.
- E1.3 The Race Committee may, at its discretion, hoist code flag “L”, (“Follow Me”) accompanied by one horn signal, and move a course to a different location.
- E1.4 Prior to the warning signal, the Race Committee signal boat will display the approximate magnetic compass course and approximate distance in nautical miles to the windward mark. The length of the course will be at the discretion of the Course Race Officer.
- E1.5 **Change of Course after the Start**
- E1.5.1 Courses may be changed in accordance with *rule 33*. A change of course after the start will be signaled before the leading boat has begun the leg, although the new mark may not yet be in position. Any mark to be rounded after rounding the new mark may be relocated to maintain the original course configuration. Also, when in a subsequent change a new mark is replaced, it will be replaced by an original mark.
- E1.6 The leg distance selected, the number of races sailed, the course area as well as any deviation in either compass heading or distance displayed by the Race Committee, shall not be cause for redress. This changes *rule 62.1 (a)*.

E2. MARKS

- E2.1 Specific mark descriptions for each course are given in Appendices E1 to E5.

E3 DIVISIONS

- E3.1 Each division shall be designated by the RC signal boat by a numeral pennant indicating the division number. Divisions will start in numerical order, but this may be changed at the discretion of the Race Committee, and shall not be grounds for redress. This changes *rule 62.1 (a)*.
- E3.2 Division splits and starting order will be posted on the Official Notice Board at Ashbridges’ Bay Yacht Club by 0800 Thursday August 2 for 3-day course racing and by 0800 Friday August 3 for 2-day course racing

E 3.3 Handicap divisions will fly identifying flags as follows. Flags will be of non-fading material, a minimum of 8" x 12" and shall be flown visibly above the stern rail. Where two colours describe flags, the order of colours will be located diagonally from top of fly to bottom of hoist, with the first named colour above the other at the hoist.

IRC 1	Black and Yellow
IRC 2	Blue and White
PHRF 1	Red and Green
PHRF 2	Code Flag "F"
PHRF 3	Code Flag "J"
PHRF 4	Yellow and Red

E4. THE START

E4.1 The start will be between the orange flag on the Race Committee boat to starboard and a pole mark or an an inflatable mark to port.

E4.2 Code Flag F (attention signal) will be displayed with one sound signal five (5) minutes before the Warning Signal for the first division to start. Code Flag F will be lowered with one sound signal one minute before the Warning Signal is made for the first division. This changes *rule 26*.

E4.3 Start Sequence:

Races will be started in accordance with *rule 26* and Instruction E3.1, as follows:

E4.3.1 For each Division, the Warning Signal will be made 5 minutes before the starting signal.

E4.3.2 There will be a minimum of one (1) minute between the Start of one Division and the Warning for the next Division.

E4.4 No start sequence will commence after 1530 hours on any course on Friday, August 3rd or Saturday, August 4th. On Sunday, August 5th, no start sequence will commence after 1330 hours on any course.

E4.5 Each succeeding race for a given division on a given day will start as soon as practicable after the finish of the previous race for that division. Within the time limits described in E3.2, the Race Committee on each course will conduct as many races per day as it deems possible.

E7. THE FINISH

The Finish Line will be between a staff displaying an orange flag on the Race Committee Boat and the adjacent Finish Mark.

E8. TIME LIMIT

E8.1 On Courses “A”, “B”, “C” “D” and “E”, the time limit for the first boat to finish will be 2 hours. Boats failing to finish within 30 minutes after the first boat in their class or Division will be scored Did Not Finish (“DNF”). This changes *rule 35*, A4.1 and A5.

E9. RACE COURSE LOCATIONS

A diagram showing the location of the four (5) Day Courses on Lake Ontario and coordinates for their respective signal boat stations shall be posted on the official notice board at ABYC by 1200 hrs on Wednesday, August 1st, 2007. Copies will also be available thereafter at the ABYC Information Center.

Appendix E1 “A” course

1 SCHEDULE

1.1 6.4 6.4 Course Diagram

The Regatta will consist of as many races as possible.

2 RACING AREA

The starting area is located inshore to the southwest of the club.

3 SIGNAL BOAT

The signal boat for this course will display SIGNAL BOAT code flag A and this may be removed just prior to the first race of the day.

4 CLASS FLAGS

Start	Classes	Class Flag
Class 1	2.4 Metre	Numeral Pennant “1”
Class 2	Martin 16	Numeral Pennant “2”

5 RADIO COMMUNICATIONS

The applicable VHF channel for this course is 68

6 THE COURSE

6.1 The compass bearing and distances to mark 1 will be displayed on the signal vessel before the warning signal.

6.2 The marks are to be tetrahedrons with a different colour change of course mark and are to be rounded as follows

6.3 Marks

Mark	Rounded to	Original Mark	Change of Course Mark
Start	N/A		N/A
1,2	Port	Tetrahedron	Tetrahedron Different Colour
Finish	N/A		N/A

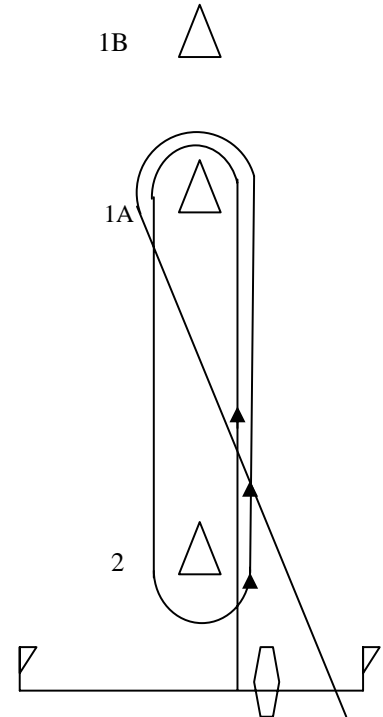

2.4 Metre shall sail Mark 1B, Mark 2, Mark 1B to finish.

Martin 16 shall sail Mark 1A, Mark 2, Mark 1A to finish.

If code flag O is flown on the Signal Boat before the start then an offset mark O will be rounded to port (1B, O, 2, 1B to finish) or (1A,O, 2, 1B to finish)

Appendix E3 “C” course

1 SCHEDULE

The Regatta will consist of a maximum of 8 races

There will be a maximum of 4 races a day.

2 RACING AREA

The starting area is centred on a point at

Lat. 43 38 .45 Degrees

Long 79 16. 40

Range and bearing from ABYC headland approx 130 degrees 1.7nm

3 SIGNAL BOAT

The signal boat for this course will display SIGNAL BOAT code flag C and this may be removed just prior to the first race of the day.

4 CLASS FLAGS & ORDER OF START

Class flags will be posted by 0800 Thursday August 2.

5 RADIO COMMUNICATIONS

The applicable VHF channel for this course is 73

6 THE COURSE

6.1 The compass bearing and distances to mark 1 will be displayed on the signal vessel before the warning signal.

6.2 The marks are to be tetrahedrons with a different colour change of course mark and are to be rounded as follows

6.3

Marks

Marks	Rounded to	Original Mark	Change of Course Mark to
Start	N/A		N/A
1,2	Port	Tetrahedron	Tetrahedron Different Colour
3S, 3P	Gate	Tetrahedron	Tetrahedron Different Colour
Finish	N/A		N/A

6.4 Course Diagram

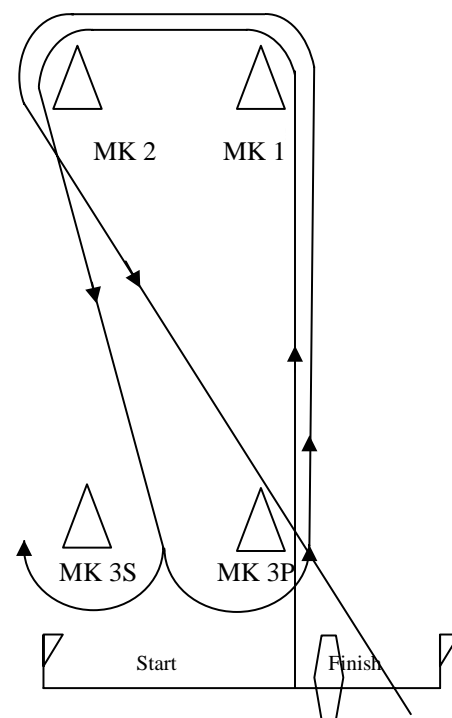

6.5 Marks 3S & 3P are not marks of the course for the first and last legs of the race

Appendix E4 “D” course

1 SCHEDULE

The Regatta will consist of a maximum of 8 races
There will be a maximum of 4 races a day.

2 RACING AREA

The starting area is centred on a point at
Lat. 43 36.25 Degrees
Long 79 19.45

Range and bearing from ABYC headland approx 202
degrees 3.2nm

3 SIGNAL BOAT

The signal boat for this course will display code flag D
and this may be removed just prior to the first race of the
day.

4 CLASS FLAGS & ORDER OF START

Class flags will be posted by 0800 Thursday August 2.

5 RADIO COMMUNICATIONS

The applicable VHF channel for this course is 72

6 THE COURSE

6.1 The compass bearing and distances to mark 1 will be displayed on the signal vessel before the warning signal.

6.2 The marks are to be tetrahedrons with a different colour change of course mark and are to be rounded as follows

6.3 Marks

Marks	Rounded to	Original Mark	Change of Course Mark
Start	N/A		N/A
1,2	Port	Tetrahedron	Tetrahedron Different Colour
3S, 3P	Gate	Tetrahedron	Tetrahedron Different Colour
Finish	N/A		N/A

1.2 6.4 Course Diagram

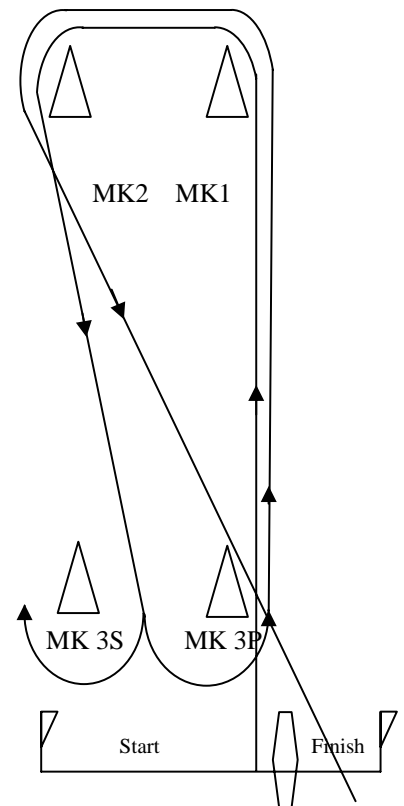

6.5 Marks 3S & 3P are not marks of the course for the first and last legs of the race

Appendix E5 “E” course

1. SCHEDULE

The Regatta will consist of a maximum of 8 races

There will be a maximum of 4 races a day.

2. RACING AREA

The starting area is centred on a point at

Lat. 43 36 .10 Degrees

Long 79 15.75

Range and bearing from ABYC headland
approx 160 degrees 3.8nm

3. SIGNAL BOAT

The signal boat for this course will display
SIGNAL BOAT code flag E and this may be
removed just prior to the first race of the day.

4. CLASS FLAGS & ORDER OF START

Class flags will be posted by 0800 Thursday
August 2.

5. RADIO COMMUNICATIONS

The applicable VHF channel for this course is
09

7 THE COURSE

7.1 The compass bearing and distances to mark
1 will be displayed on the signal vessel before
the warning signal.

7.2 The marks are to be tetrahedrons with a
different colour change of course mark and are
to be rounded as follows

7.3 Marks

Mark	Rounde s d to	Original Mark	Change of Course Mark
Start	N/A		N/A
1,2	Port	Tetrahedron	Tetrahedron Different Colour
3S, 3P	Gate	Tetrahedron	Tetrahedron Different Colour
Finish	N/A		N/A

7.4 Course Diagram

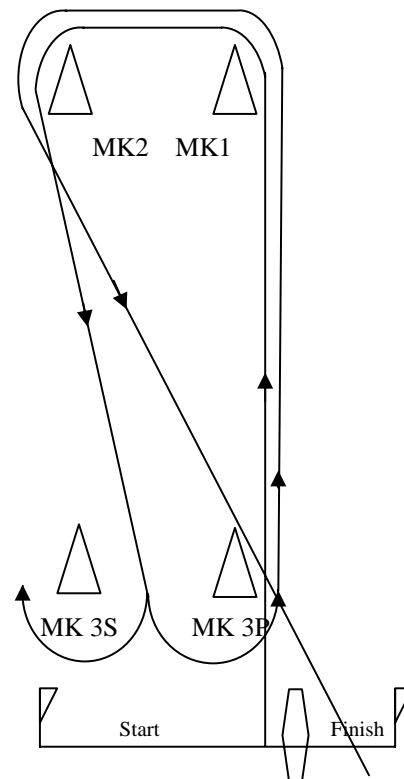

7.5 Marks 3S & 3P are not marks of the course
for the first and last legs of the race

Appendix F – Prizes

1. LYRA 2007 Regatta awards will be presented to the skippers of the boats placing first, second, and third in each division in the Long Distance Races and the Day Course Race Series.
2. In the Centennial and Founders Cup Races, boats placing first in each Division will be awarded place plaques, place flags and crew prizes. Boats placing second and third in each Division will receive place plaques and place flags. In addition, the following perpetual trophies will be awarded:

Centennial Race

IRC fleet, first corrected:	<i>Centennial Cup—IRC</i>
PHRF-LO fleet, first corrected:	<i>RYC Centennial Trophy</i>
Eight Metre, first:	<i>Canada Cup Centennial Trophy</i>

Founder's Cup Race

PHRF-LO fleet, first corrected:	<i>Oswego YC Founders Cup</i>
---------------------------------	-------------------------------

3. In the Long and Short Freeman Cup races, boats placing first in each Division will be awarded place plaques, place flags and crew prizes. Boats placing second and third in each Division will receive place plaques and flags. In addition, the following perpetual trophies will be awarded:

Freeman Races

First monohull to finish, Long or Short Course, regardless of fleet, class or division:

Olcott Cup

Long Freeman Cup Race – IRC :

Fleet, Best elapsed time:	<i>Yacht Racing Union Cup</i>
First, fleet corrected:	<i>Charles Freeman Cup</i>
Second, fleet corrected:	<i>Founders Cup</i>
Third, fleet corrected:	<i>Douglas B. Jones Trophy</i>
Division Winners:	<i>Golden Eagle Trophy</i> <i>IRC II Bowl</i> <i>IRC III Bowl</i>

Long Freeman Cup Race - PHRF-LO

Fleet, Best elapsed time:	<i>Sodus Bay Cup</i>
First, fleet corrected:	<i>Louise Freeman Cup</i>
Second, fleet corrected:	<i>LYRA PHRF-LO Trophy</i>
Third, fleet corrected:	<i>Johnstone Trophy</i>
Division Winners:	<i>Simplicity Trophy</i> <i>Tom Taylor Trophy</i>

Short Freeman Cup Race - PHRF-LO

Fleet, Best elapsed time:	<i>Queen City YC Trophy</i>
First, fleet corrected:	<i>ABYC Trophy</i>

Division Winners: *Presidents Trophy*
 National YC Trophy
 LYRA Oval Tray

4. In the Day Course Race Series, boats placing first in division will be awarded place plaques, place flags and crew prizes. Boats placing second or third in each division will receive place plaques and place flags. In addition, the following perpetual trophies will be awarded:

Day Course Race Series - IRC

First overall in fleet: *City of Toronto Mayor's Trophy (see 23.6)*
Division Winners: *Lake Ontario Trophy*
 Baldwin Trophy

Day Course Race Series - PHRF-LO

First overall in fleet: *City of Hamilton Mayor's Trophy (see 23.6)*
Division Winners: *John C. Mott Trophy* *PHRF-LO Executive's Cup*
 Accommodation Cup *Bulldog Trophy*
 Frederic Nichols Trophy
 John Labatt Trophy
 Hinterhoeller Trophy
 PHRF-LO Presidents Cup
 PHRF LO Handicapper's Cup

Day Course Race Series - One Design

Classic 8 Metres: *Commodore Gooderham Trophy*
Modern 8 Metres: *Sean Spacher Memorial Trophy*
J/22, or largest small boat
 one-design fleet: *The Bud Doyle Trophy*
C&C 35 Mk III: *Commodore World Trophy*
C&C 29: *Castle Cup*
O-D Fleet 6: *Hispaniola Trophy*
O-D Fleet 7: *Montgomery Trophy*
Largest C&C Fleet: *George Cuthbertson Trophy*

5. In any race or series, the last place boat in a division may not win a division trophy or flag. It is understood that if there is only one boat in a division, it is the last boat.
6. For First Overall Performance in the Day Race Series in the IRC fleet (*The City of Toronto Mayor's Trophy*) and the PHRF Fleet (*City of Hamilton Mayor's Trophy*), the winners in their respective fleets shall be determined via the Cox-Sprague scoring method.
- 7 The US/Canada Challenge (for the *PCYC Fortuna Trophy*) applies to all races run during the LYRA 2007 Regatta and will be scored as a separate race event, complete with its own race summary. If possible, the trophy will be awarded during the Day Course Race Awards presentation on August 5th. If not, the trophy will be presented at the LYRA Annual General Meeting in November.

The scoring formula, developed by Ted Ison of Kingston Yacht Club, is as follows:

- a) The first finisher from a team (country) gets his/her position scored on the High Point System
- b) Subsequent finishers from the same team, get their position (scored on the High Point System) divided by the total number of competitors from their team.
- c) This means that the best finisher from a team gets points equal to his/her position, while the finishes for the other team members are "averaged". The scores for all of the competitors from a team are then totaled to give that team's score. The highest total team score wins.
- d) The formula is applied to the fleet as a whole, regardless of the gender of the competitors.
- e) The winning team shall be awarded the *Fortuna Trophy* (a perpetual trophy) and it shall be displayed at the host club of the current year's LYRA Regatta until it is awarded again.

8. LYRA REGATTA CHAMPIONSHIPS IN IRC, PHRF, AND ONE-DESIGN

8.1 Qualification

- 8.1.1 To qualify for the **LYRA Regatta Champion in PHRF or IRC**, a yacht must race the Freeman Cup Long Course Race, the Day Race Series and either the Centennial or Founder's Race.
- 8.1.2 A yacht must compete in one fleet only (IRC or PHRF) for all races needed to qualify in 1.1.
- 8.1.3 To qualify for **LYRA Regatta Champion in One-Design**, a yacht must race in a One-Design class in the Day Race Series and either PHRF, IRC or One-Design in the Centennial or Founder's Race and the Freeman Cup Race (Long or Short course).
- 8.1.4 Yachts racing in Level Rating and/or MORC divisions are ineligible for any of the Regatta Champion awards.

8.2 SCORING

- 8.2.1 The LYRA Regatta Champions in IRC, PHRF and One-Design fleets shall be determined using the widely recognized Cox-Sprague scoring method. A weighting factor shall be applied as follows:
 - = 0.5 for the Centennial or Founder's Race
 - = 1.0 for the Freeman Cup Long Course Race
 - = 0.30 for each Day Race
- 8.2.2 All races shall be scored (no throwouts). The yachts with the highest percent perfection in the IRC, PHRF and One-Design fleets shall be the Regatta Champions, respectively. The LYRA Executive Committee reserves the right to not award one or more of the three Regatta Champion awards if, in its opinion, the performance of the yacht with the highest percent perfection is not commensurate with the "best in fleet" spirit of the awards. The decision of the LYRA Executive Committee is final and not subject to redress or protest.

8.3 8.3 AWARDS

8.3.1 Special pennants will be awarded to the IRC, PHRF and One-Design Regatta Champions. In addition, the following LYRA perpetual trophies will be awarded:

- Bamaan Trophy**.....LYRA Regatta Champion, IMS
- Lake Ontario PHRF Trophy** LYRA Regatta Champion, PHRF
- Kay Heron Trophy** LYRA Regatta Champion, One-Design

8.3.2 If at all possible, these awards shall be presented at the LYRA Regatta as part of the awards presentation on Sunday, August 5, 2007. If not, they will be presented at LYRA's Annual General Meeting in November, 2007

8.3.3 Perpetual trophies are to be returned to LYRA at or before the start of the 2008 LYRA Regatta.

8.3.4 Recipients of the above trophies assume full responsibility for their safekeeping, cleaning/polishing and return.